

Models BV10 & BV11 On/Off Solenoid Operated Valves

Description

The Model BV10, normally closed, and BV11, normally open, solenoid operated Brodie Control Valves are designed for remote on-off flow control. They are externally piped with a needle valve (speed of response control) and strainer as standard equipment.

Principle of Operation

The valves are pilot operated and operate on a balanced piston principle, spring biased to a closed position. Pressure differential overcomes the force of the spring, causing the main valve to open and establish flow. The pilot varies the pressure on the spring side of the piston for position.

Design Features

- Modular construction - All internal parts including seat ring can be removed with the cylinder assembly without disturbing line connections.
- No diaphragms or stuffing boxes
- 45° body design assures high capacity
- Positive shut-off
- Uniform speed of response
- Linear control characteristics
- Inherently checks reverse flow

“AP” (Aggressive Products) Option

The “AP” option valve cylinder incorporates a combination of seals and O-ring materials to provide optimum performance in aggressive product applications. Specify “AP” Option at time of order when valve is to be used on products which may affect standard seals.

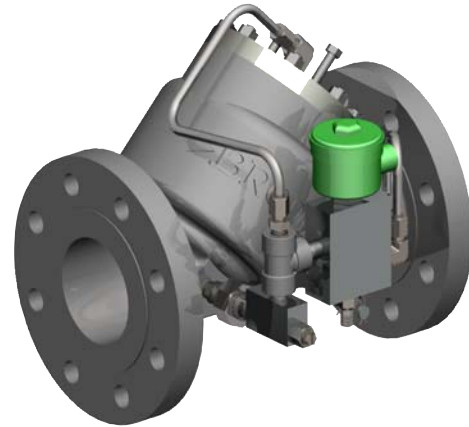

WARNING

Do NOT operate this instrument in excess of the specifications listed. Failure to heed this warning could result in serious injury and/or damage to the equipment.

Valve Capacity Data

Valve Size	2"	3"	4"	6"
*Cv-gpm	90	190	315	700

*Cv based on wide open valve utilizing water at 60F (15.6C).

Typical Installation

Closed Position

The solenoid pilot is closed (N.C. illustrated). Y=port (P3) to Z=port (P2) is closed. X-port (P1) and Y-port (P3) pressures are balanced. The main valve spring, being the differential force, closes the piston and keeps it seated. The needle valve controls the speed of closure.

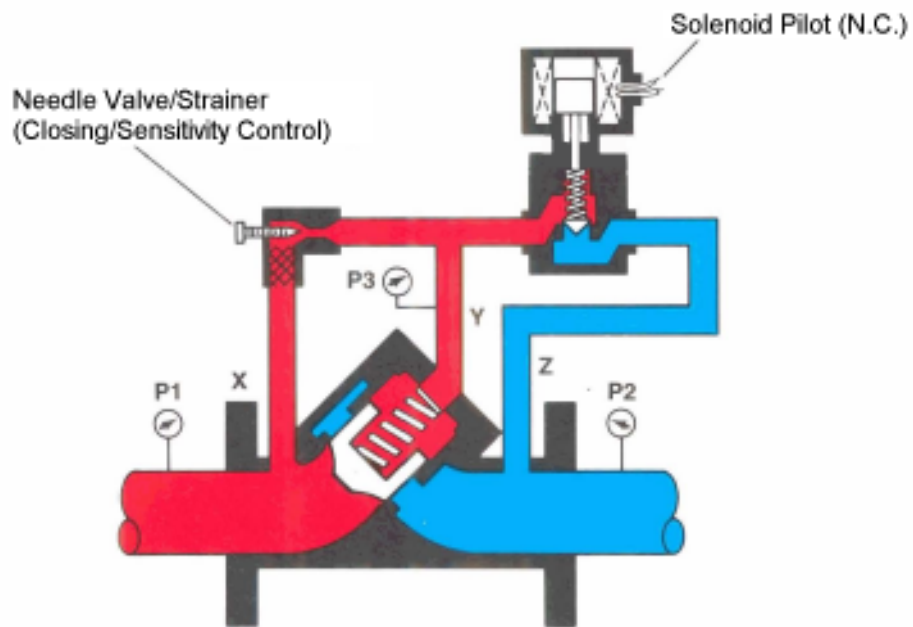

 = Inlet Pressure
 = Outlet Pressure

Open Position

The solenoid pilot is open. Y-port (P3) is open to Z-port (P2). The pressure on the bottom of the piston (P1) is greater than the pressure at (P3) plus the spring force. $(P1 \text{ minus } P2)$ is equal to or greater than the spring force.

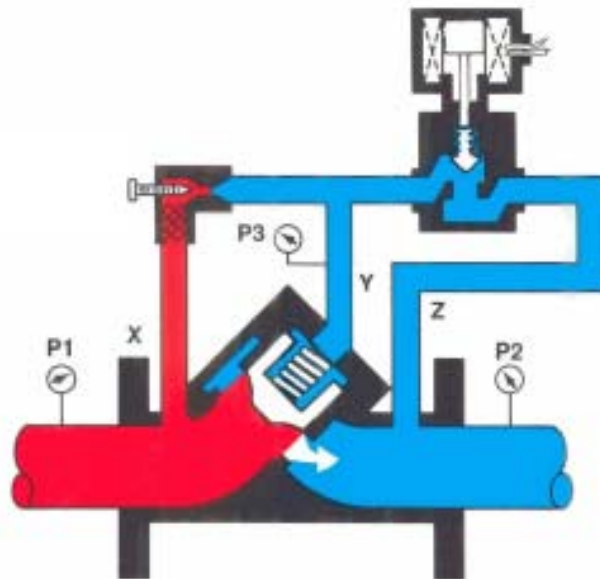

 = Inlet Pressure
 = Outlet Pressure

Materials of Construction

Main Valve Body: Steel-ASTM-A216-GR-WCB

Main Valve Cylinder: 17-4 Stainless Steel

Main Valve Piston: Stainless Steel

Seat Ring: Stainless Steel

O-Rings: Viton Standard

(Other elastomers available)

Other Internal Parts: Stainless Steel

Pilot Valve Strainer/Needle Valve Strainer:

Standard: Steel

Tubings and Fittings: Standard: Steel

Optional Equipment

- Valve Position Indicator
- Position Indicator Switches
- Independent Opening Speed Control
- Stainless Steel Tubing
- Thermal Relief
- Pilot Line Isolation Block Valves
- Manual Override (Opens Valve)

Recommended Spare Parts

O-Rings

Flange Connections

Valve Size	Connections	Max Working Pressure @100F	DIN Connections	Max Working Pressure
3"-6"	150 lb. ANSI	285 PSI	DN 80-DN150 PN 25	25 Bar
3"-6"	300 lb. ANSI	740 PSI	DN 80-DN150 PN 64	51 Bar

Temperature Range: -20F to 150F (-29C to 66C) Optional 250F (121C)

Dimensions (For Certified Dimensional Prints - Consult Factory) Pilot Spring Ranges

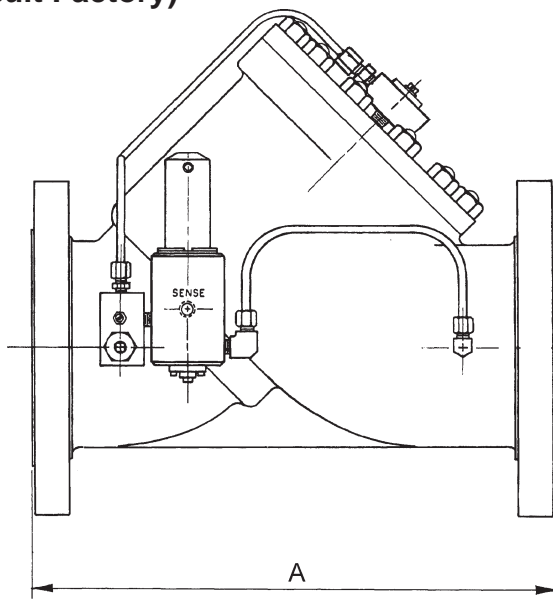

Valve Size	Dimensions		
	mm	150 lb.	300 lb.
2"	mm	260	N/A
	Inches	10 1/4	
3"	mm	279	333
	Inches	11	
4"	mm	330	368
	Inches	13	14 1/2
6"	mm	432	454
	Inches	17	17 7/8

150-300 lb. Valves	
(PSI)	(kPa)
0-20	0-138
*0-40	0-276
30-80	207-552
70-180	483-1241
150-350	1034-2413
350-650	2413-4482

* Spring selection based on control pressure set point.

Shipping Weight and Volume (Approximate)

2"	69 lbs. @ 3 Cu. Feet 31.3 kgs. @ .085 Cu. Meters
3"	105 lbs. @ 2.36 Cu. Feet 47.63 kgs. @ .067 Cu. Meters
4"	140 lbs. @ 2.51 Cu. Feet 63.5 kgs. @ .071 Cu. Meters
6"	250 lbs. @ 4.84 Cu. Feet 113.4 kgs. @ .137 Cu. Meters

Ordering Information

In order to accurately process an order, such information as product to be controlled, product viscosity, product temperature range, ambient temperature range, rate of flow, operating pressure, units of registration, accessories required, and optional features needed must be specified by the customer.

The contents of this publication are presented for informational purposes only, and while every effort has been made to ensure their accuracy, they are not to be construed as warranties or guarantees, express or implied, regarding the products or services described herein or their use or applicability. Brodie Meter Co., LLC reserves the right to modify or improve the designs or specifications of such products at any time without notice.

BRODIE
International

19267 Highway 301 North (30461)
PO Box 450 • Statesboro, GA 30459-0450
Phone: (912) 489-0200 • Fax: (912) 489-0294
www.brodieintl.com