

E3000 TOP LOADING SKID | COMPLETE WITH METERING LINE

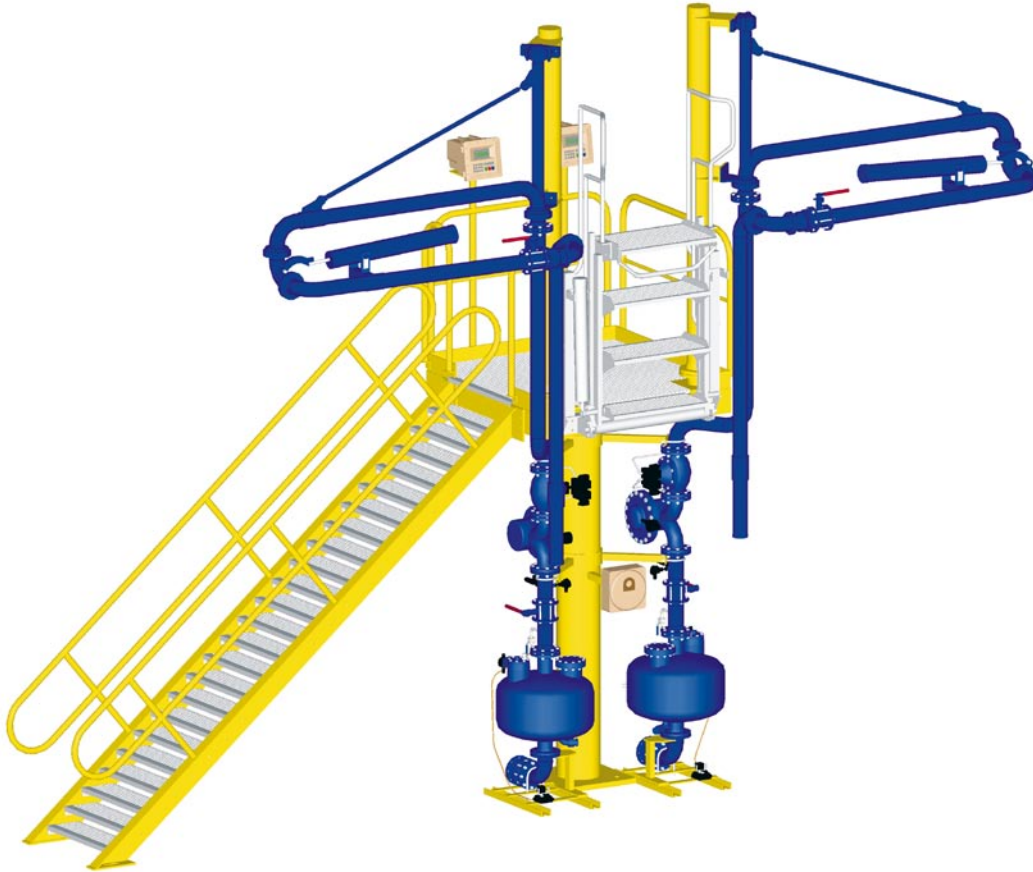

FEATURES

- * Complete skid in compact design
- * Shortest installation time at site
- * No extra engineering
- * Limited interfaces
- * Single supplier from design to commissioning
- * Approved components for any application

E3000 TOP LOADING SKID

E3000 TOP LOADING SKID | COMPLETE WITH METERING LINE

ENVELOPE DRAWING

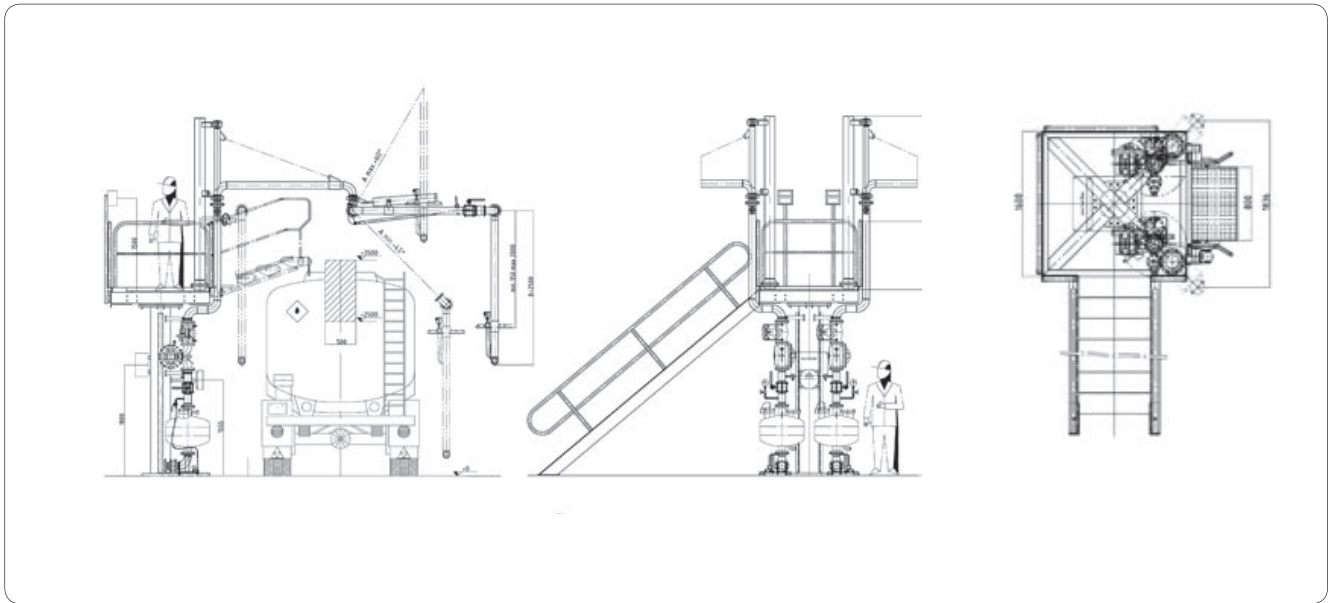

COMPONENTS

- * Loading platform in standard or customized design
- * Loading arm individually for the specific products
- * Folding stairway
- * Mass or flow meter from different suppliers
- * Control valve (pneumatically, hydraulically, electronically)
- * Filter / air eliminator
- * Control units / boxes, batch controllers

APPLICATIONS

- * All oil and refined oil products
- * Food and hygienic industry
- * Chemical industry
- * Single loading applications
- * Complete loading terminals
- * Train, truck and any other compartments

EMCO WHEATON carbon steel swivel joint with flame hardened ball race way for a long life time!

For more details see our data sheet swivel joint **D2000**.



Better by
Design



EMCO WHEATON

A Gardner Denver Product

EMCO WHEATON GmbH

Emcostraße 2-4 · 35274 Kirchhain · Germany

Phone +49 6422 84-0 · Fax +49 6422 5100

www.emcowheaton.com · assist@emcowheaton.com

Whilst the content of this leaflet has been edited with the greatest care, we are not liable for any errors and/or omissions. Subject to change without notice.

Top loading skid EN 05/08