

## | CONTROL SYSTEMS

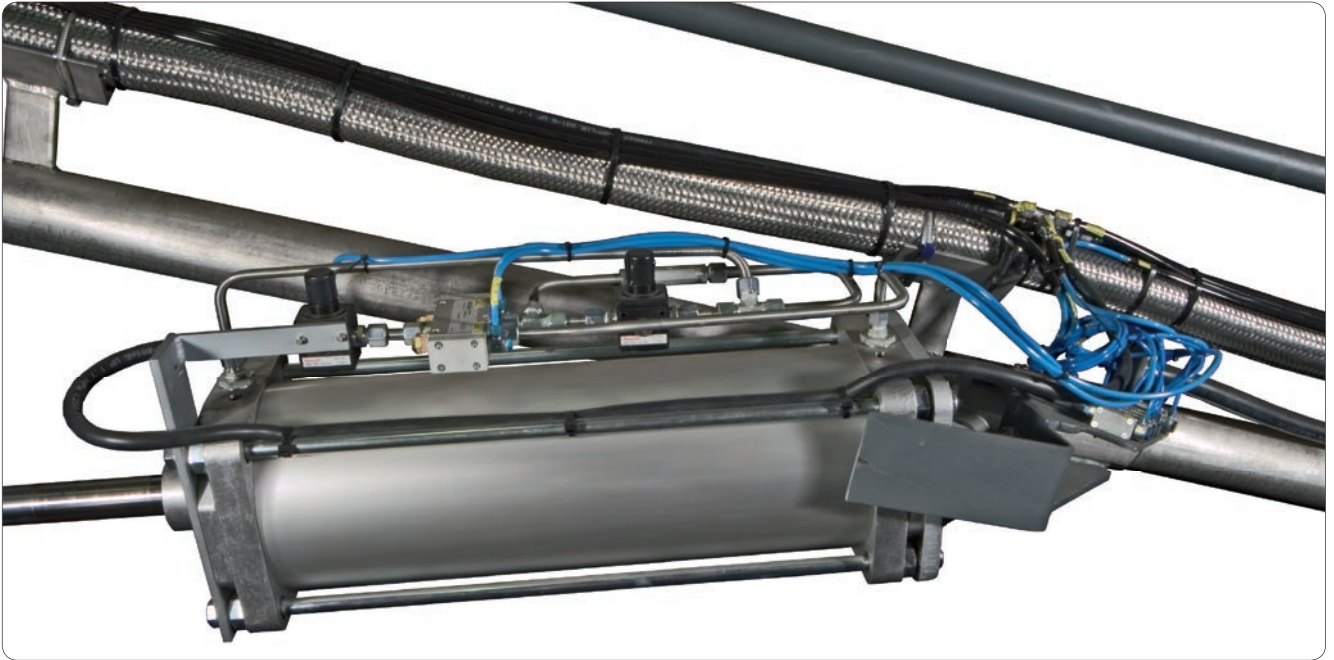

| Pneumatic control system

### FEATURES

- \* Highest reliability by use of quality approved components
- \* Individual design
- \* Completely assembled, proved and checked prior delivery
- \* User friendly operation

EMCO WHEATON supplies individual control systems for comfortable and safe operation of loading arms.

Depending on the application design of the control systems can be mechanic, pneumatic or hydraulic.

# CONTROL SYSTEMS

# CONTROL SYSTEMS

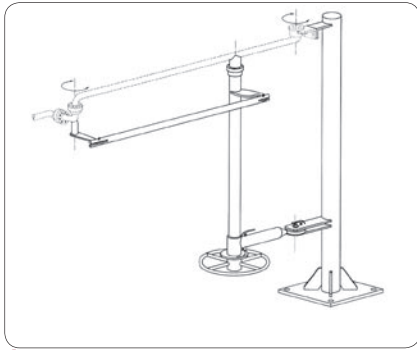

E0577 – Double slewing device

## DOUBLE SLEWING DEVICE

Kind of movement:

- \* Horizontal

The double slewing device controls the horizontal slew, and the arresting in parkposition of the loading arm from the bottom.

The "F"-tube is slewed by moving the whole device and the "A"-tube is slewed by operating the handwheel via the connecting rod.

The device is used on installations where there is no loading gantry. The height of the standpost is arbitrary.

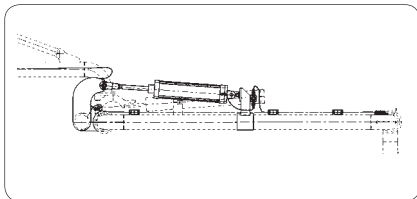

E0397 – Hold down device  
E0651 – Pneumatic actuator

## HOLD DOWN DEVICE

Kind of movement:

- \* Horizontal

The loading arm is balanced through spring cylinder or counterweight. The cone or the adapter plate will be pressed to the manhole by use of a separate pneumatic cylinder.

## PNEUMATIC ACTUATOR

Kind of movement:

- \* Hold down
- \* Vertical movement

The pneumatic actuator is used for the up and down movement as well as pressing the loading arm on the top of the manhole. The balancing is carried out by spring cylinder or counterweight. Operated by handlever pendant push button (2 or 3 buttons).



E0902 – Pneumatic cylinder

## PNEUMATIC CYLINDER

Kind of movement:

- \* Hold down
- \* Vertical movement
- \* Balancing

The pneumatic cylinder is used for the up and down movement and pressing the loading arm on the top of the manhole. Operated by handlever pendant push button (3 buttons).

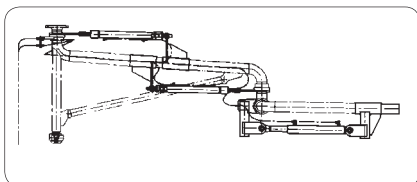

E0705 – Hydraulik system

## HYDRAULIC SYSTEM

Kind of movement:

- \* Hold down \*
- \* Vertical movement
- \* Horizontal movement
- \* Balancing \*

The hydraulic system enables remote loading arm control. It will be used for arms which are unable to be operated manually – either by its weight or site conditions.

\* if applicable



Electrical control

## ELECTRICAL CONTROL

Kind of movement:

- \* Vertical movement
- \* Horizontal movement

The electrical control will be used for special hygienic requirements or where a high control precision has to be achieved. The balancing is carried out by spring cylinder or counterweights. Special designs are possible, e.g. full automatic control systems.

**EMCOWHEATON**

A Gardner Denver Product

Better by Design



EMCO WHEATON GmbH  
Emcostraße 2-4 · 35274 Kirchhain · Germany  
Phone +49 6422 84-0 · Fax +49 6422 5100  
www.emcowheaton.com · info-de@emcowheaton.com