

TELESCOPIC DROP TUBE



THE FOLLOWING SITUATIONS REQUIRE THE USE OF A TELESCOPIC DROP TUBE

- * Internal friction in flowing products can cause electrostatic charge. This physical effect can lead to sparking which is mandatory to be avoided – especially when combustible or explosive fluids are loaded. Sparking prevention can be achieved most efficiently by creating bottom contact with a telescopic drop tube.
- * Bottom contact with a telescopic drop tube is recommended for loading of foaming products.
- * For loading applications with height restrictions (e.g. by a roof) a telescopic drop tube is the ideal solution compared with a long and rigid drop tube.

Telescopic drop tubes can be either manually or pneumatically operated. Manually operated telescopic drop tubes are robust and have a short installation length.

PNEUMATIC OPERATION CAN BE ACTUATED BY

- * Pneumatic cylinder or
- * P pneumatic motor

FEATURES

- * design with cone or cover plate
- * easy Handling

TELESCOPIC DROP TUBE

TELESCOPIC DROP TUBE

DIMENSIONS AND TECHNICAL DATA

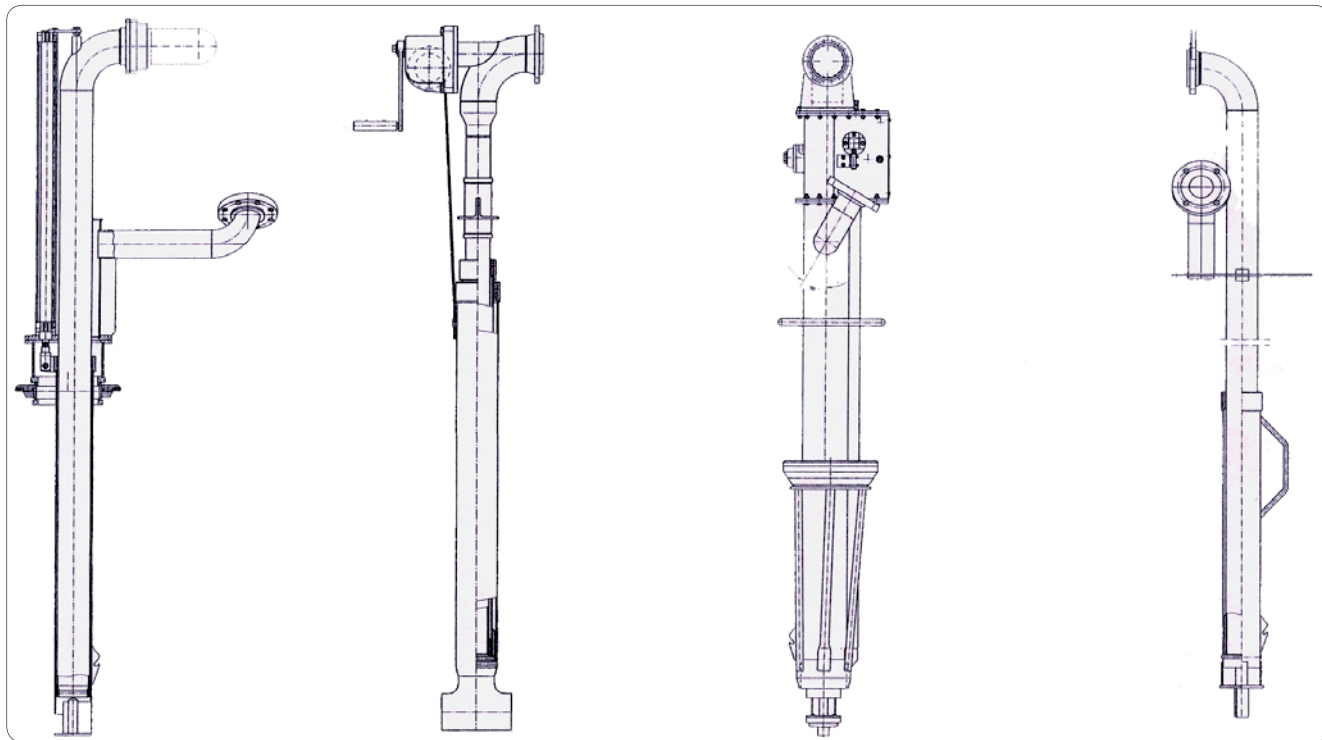

DN (Standard)	Material	Protective accessories
80	Aluminium	Monitoring of bottom contact
100	Stainless steel	Overflow prevention device
Other sizes on request		

When vapour return is required it is usually necessary to close the man hole.

For details regarding vapour return please see data sheet E2630 / E2632.

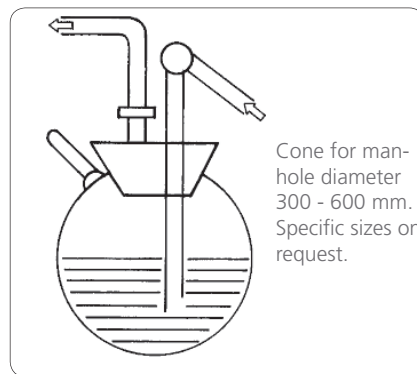
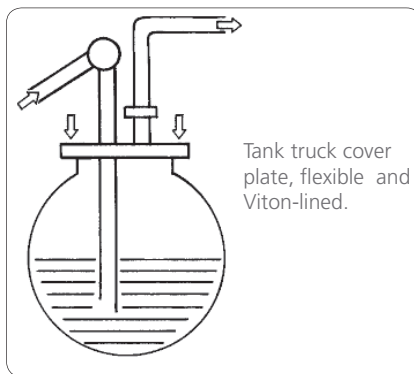

MATERIAL

- * Stainless steel
- * Aluminium
- * Carbon steel, lined
- * Plastic

LINING

- * EPDM
- * Viton

Special designs on request.

EMCOWHEATON

A Gardner Denver Product

Better by Design



EMCO WHEATON GmbH
Emcostraße 2-4 · 35274 Kirchhain · Germany
Phone +49 6422 84-0 · Fax +49 6422 5100
www.emcowheaton.com · info-de@emcowheaton.com