

HRS | HOSE RELEASE SYSTEM

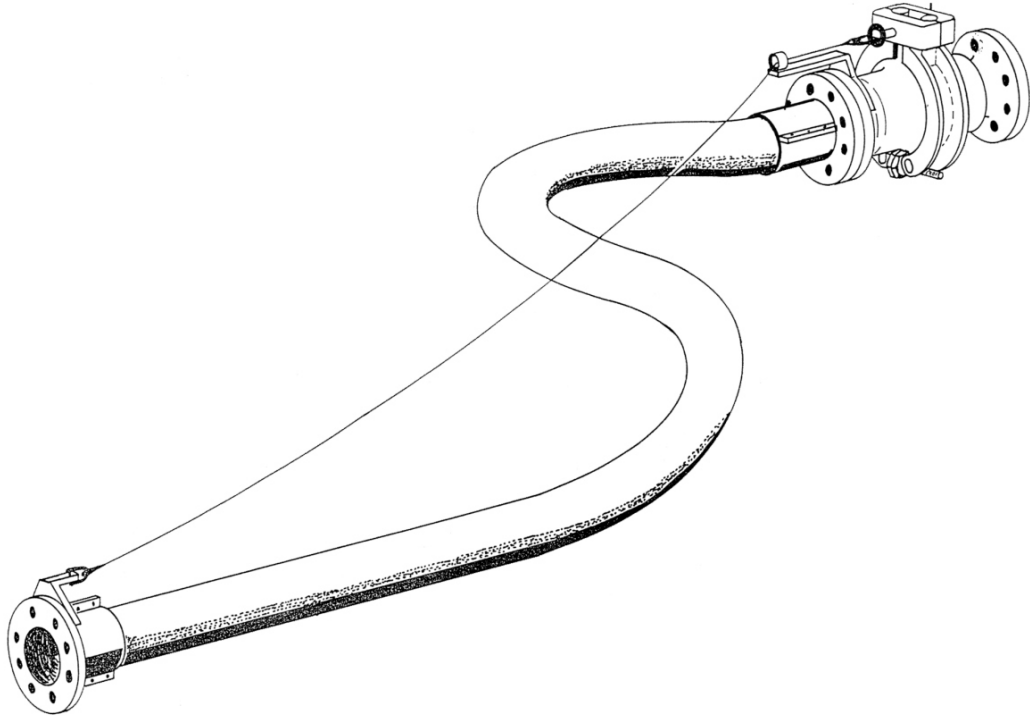

FEATURES

- * Reliable
- * Easy handling
- * Environmentally friendly

The Hose Release System is used for the protection of loading hoses during loading/unloading of barges.

EMCO WHEATON GmbH herewith contribute to environmentally safe handling of loading hoses.

HOSE RELEASE SYSTEM

HRS | HOSE RELEASE SYSTEM

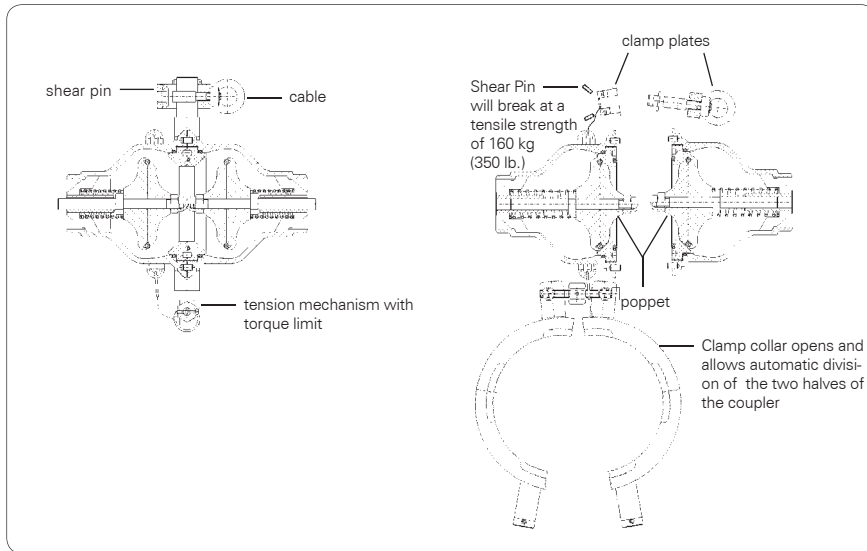

If the connected loading hose is stretched over the allowable working envelope, the cable will be activated.

The shear pin breaks, the clamp plates fall down and the clamp collar of the release unit will unlock.

The two halves of the coupler will divide before parts of the installation and the vehicle can be damaged.

SWIVEL JOINT ASSEMBLY

Variant	DN	P	T	H	Q	M
-007	50	60	20	446	250	176
-008	80	60	20	485	327	215
-009	100	80	25	603	403	263

The spring loaded poppets cut the product flow of the hose and the vehicle completely so that leakage will be avoided.

The hose release system is available in sizes from DN80 to DN100 and up to PN40.

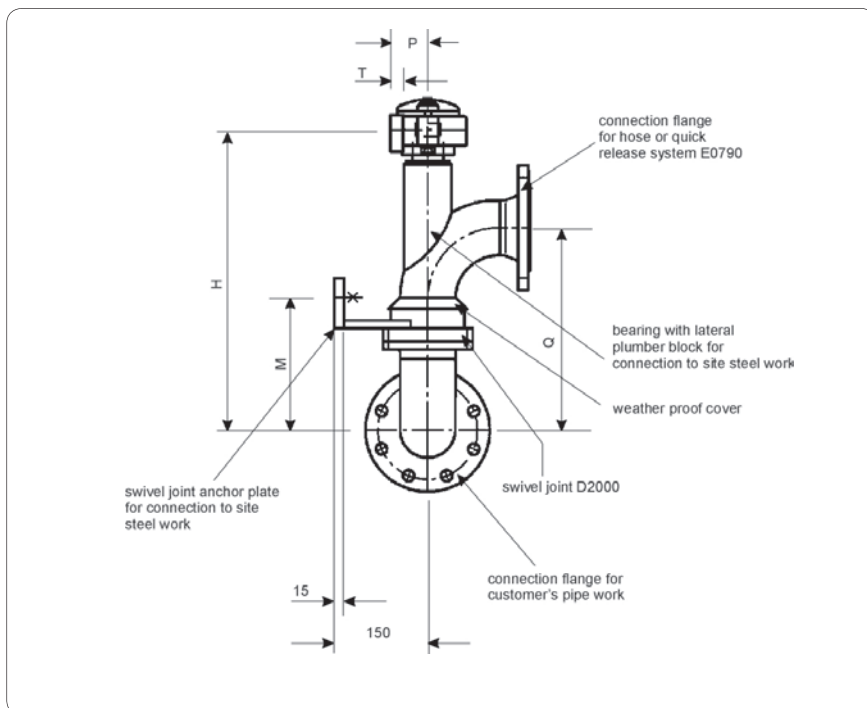

Better by Design



EMCOWHEATON

A Gardner Denver Product

EMCO WHEATON GmbH
 Emcostraße 2-4 · 35274 Kirchhain · Germany
 Phone +49 6422 84-0 · Fax +49 6422 5100
 www.emcowheaton.com · info-de@emcowheaton.com