

AIR INTERLOCKS

F0567

METAL AIR INTERLOCK VALVE

EMCO WHEATON

A Gardner Denver Product

FEATURES & BENEFITS

The F0567 Metal Air Interlock is designed for installation on API Adaptors, Vapor Adaptors, and Guardbar Systems. It can be used for interlocking a vehicles brakes or controlling other pneumatic components.



- **Electrically continuous** to prevent the build up of static electricity
- **Stainless steel** operating shaft, spring, end cap and button eliminates corrosion
- **Zinc plated** bolt location inserts
- **Reversible mounting** for different height requirements and applications
- **¼" NPT** Air Connections
- **Adjustable button** for different couplings and applications
- **Different end buttons** are available to suit the specific application
- **Electronic limit switch** available



As a part of a continuous commitment to product development the company reserves the right to alter the specification of its products without prior notice

Emco Wheaton Fuel Systems
Gardner Denver Inc.
306 Middletown Park Place, Suite D, Louisville, KY 40243 USA
Tel: +1 800 285 EMCO (3626) Fax: +1 502 489 3882
e-mail: assist@emcowheaton.com www.emcowheaton.com

OVERALL DIMENSIONS

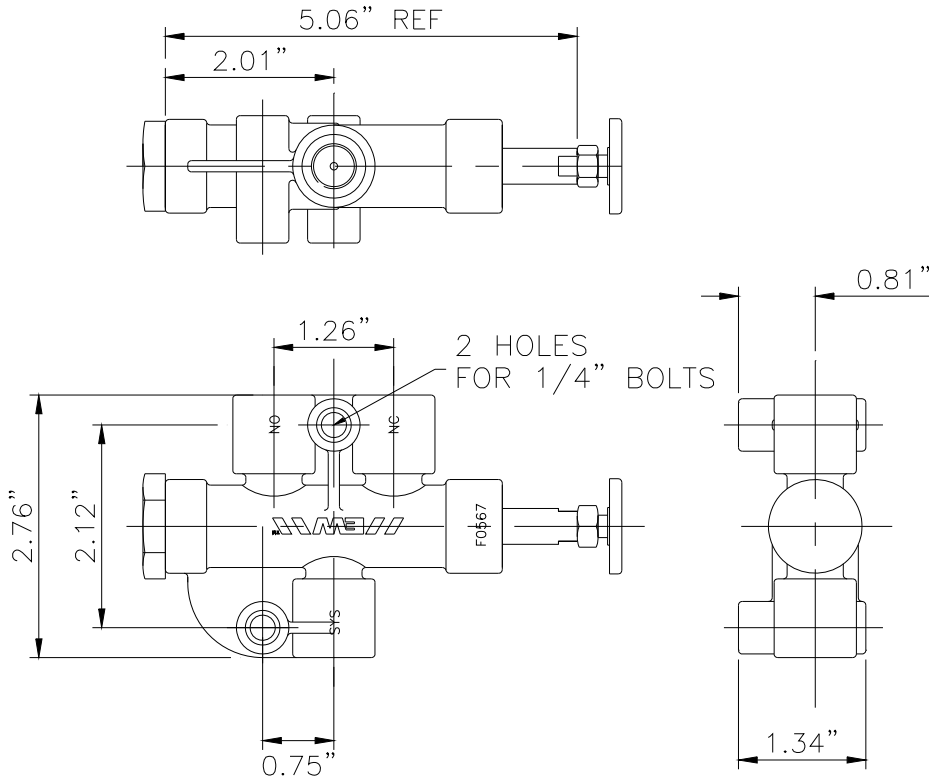

VARIANTS

PART NO.	DESCRIPTION	WEIGHT
F0567-501	Metal Air Interlock with 1" Button	0.50
F0567-511	Metal Air Interlock with 1.5" Button	0.50
F0567-521	Metal Air Interlock with Butterfly Button	0.52

Sheet Ref. CSF0567-5
Oct 2009 - Revision 0

As a part of a continuous commitment to product development the company reserves the right to alter the specification of its products without prior notice

*Better by
Design*

EMCO WHEATON

A Gardner Denver Product

Emco Wheaton Fuel Systems
Gardner Denver Inc.
306 Middletown Park Place, Suite D, Louisville, KY 40243 USA
Tel: +1 800 285 EMCO (3626) Fax: +1 502 489 3882
e-mail: assist@emcowheaton.com www.emcowheaton.com