

F0523 | DROP ELBOWS. 4" PRODUCT DELIVERY ELBOW

The NEW F0523 product delivery drop elbow is designed with the operator in mind. It is strong, lightweight with a low pressure drop to reduce delivery times. We asked operators and drivers what they wanted to see in the next generation F0523 and we have delivered.

FEATURES & BENEFITS

- * **Heavy duty** construction throughout
- * **Lightweight** rugged aluminum construction
- * **High strength** solid bronze interlocking cams, prevents loosening
- * **High flow-rates** low pressure drop design
- * **Smooth** action side-locking handle with stainless steel linkage
- * **Safety** latch build in as standard
- * **Tall** version as standard for deep boxes – no need for expensive extension kits and added leak-points
- * **Thick** chemical resistant sightglass with 360° visibility
- * **Stainless** steel high strength fasteners (no split pins)
- * **Bushings** on all running surfaces for extended life
- * **Ergonomic** balanced carrying handle
- * **Easily** fits in standard trailer cabinets
- * **Dry lube** operation, to eliminate that greasy mess



**SPECIFY EMCO WHEATON
FOR THE HIGHEST FLOW**

F0523

F0523 | DROP ELBOWS. 4" PRODUCT DELIVERY ELBOW

OVERALL DIMENSIONS

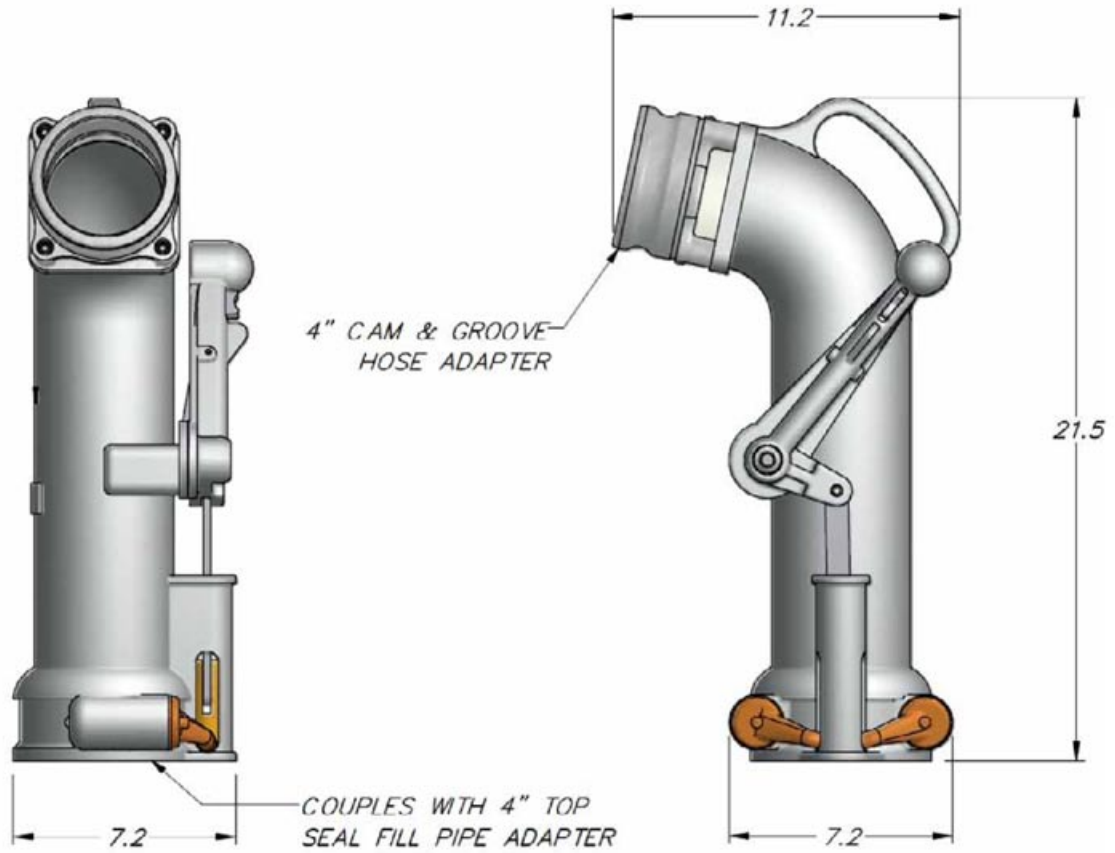

VARIANTS

Part number	Description	Weight
F0523-106	Product Drop Elbow 4" Base x 4" C&G	16.5 lbs

Sheet Ref. CSF0523-1 - Oct 2009 - Revision 0

Better by Design



EMCO WHEATON

A Gardner Denver Product

EMCO WHEATON Fuel Systems
Gardner Denver Inc.

306 Middletown Park Place, Suite D, Louisville, Ky 40243 USA
Toll Free: +1 800 285 EMCO (3626) · Phone +1 502 489 3884 ·

Fax +1 502 489 3882

www.emcowheaton.com · assist@emcowheaton.com