

1. Application

This quick release system provides automatic disconnection of a loading arm in the event of a tanker accidentally driving away. Simultaneously the product flow will be shut off both upstream and downstream of the disconnection point.

The system can be used on a variety of loading applications.

2. Description

The main components of the systems are:

- release unit with integral shut off valves
- connecting flange sensor
- pneumatic control system
- shear pin

The quick release unit is fitted as an integral part of the outboard end (B-dimension) of the loading arm. Both valves are clamped together by a collar assembly. The clamp is released by a pneumatic cylinder. A limit switch fitted to the double swing joint, and controlling the rotation angle, activates the cylinder.

The connecting flange sensor and a shear pin, also fitted to the double swing joint, prevent accidental release whilst manoeuvring the loading arm.

The sensor consists of a probe at the connecting flange face, a pneumatic hose attached along the loader, an air flow regulator, a pressure switch and an indicator. Also integrated in the system is a P/E-transformer which switches a voltage free signal for additional control functions (e.g. PUMP ON). All components are fitted to a control box. This box is fixed to the standpost. Fitted into the air supply line of the control box is a shut-off valve and a pressure regulator.

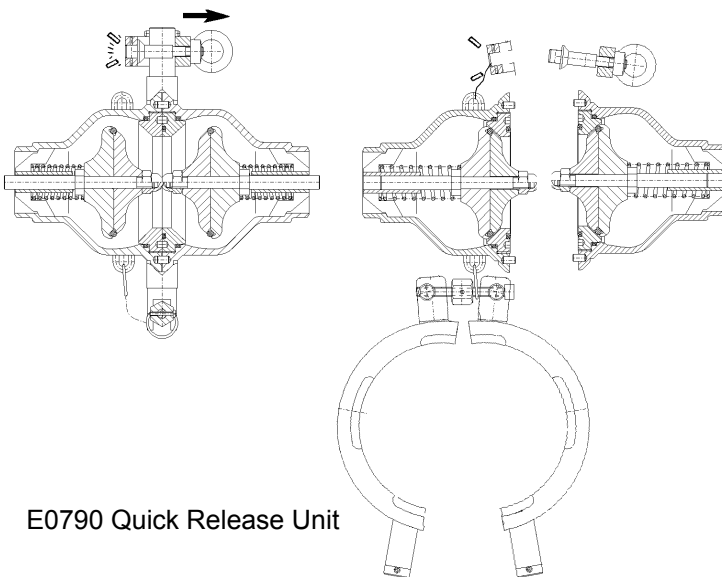

E0790 Quick Release Unit

3. Method of operation

An adjustable air stream goes through the probe. When connecting the loading arm to the tanker the air stream is stopped. The pressure switch then gives air pressure to the limit switch. Simultaneously the P/E-transformer is switched and the indicator for LOADING ARM CONNECTED is activated.

If the loading arm is pulled outside of its safe working envelope, while connected, the following sequence of events will take place:

- The shear pin is broken
- The limit switch activates the cylinder.
- This shears the locking pin, opening the collar, and the quick release unit separates into two halves.
- Both spring loaded shut off valves close.
- With the outboard end of the arm released, the counterbalance of the arm is affected and the arm will move vertically back to the parked position.

Following an emergency release we recommend that reassembly is carried out by authorized personnel (EMCO service engineer). To carry this out both the loading arm and the disconnected outboard end must be drained of product. The outboard end must be removed from the tanker, and the quick release unit reassembled in accordance with Operation and Maintenance Manual. New shear and locking pins must be fitted.

4. Technical Data

- The system requires dry and clean instrumental air of min 4 bar. The flow regulator is adjusted at 50 NI/hour.
- Release unit:
Material: stainless steel ASTM A 316
Seal: EPDM
Working pressure: PN 40

