

The Hose Release System is used for the protection of loading hoses during loading/unloading of road and rail tankers. Emco Wheaton GmbH herewith contribute to environmentally safe handling of loading hoses.

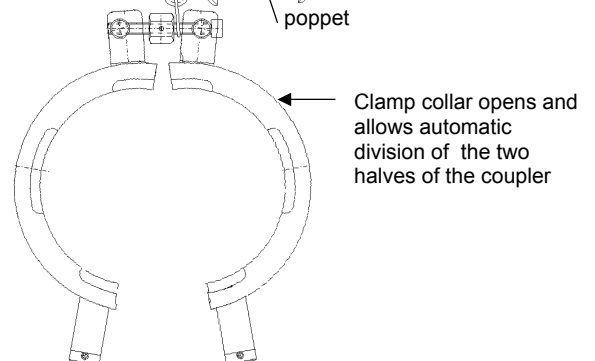
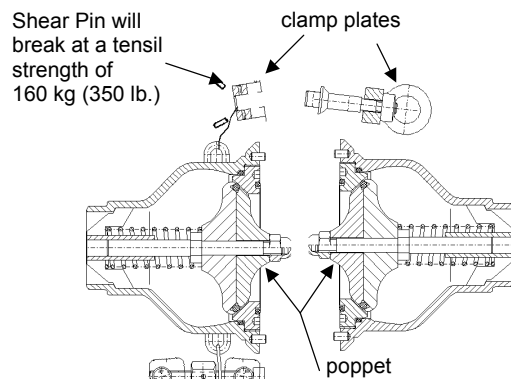
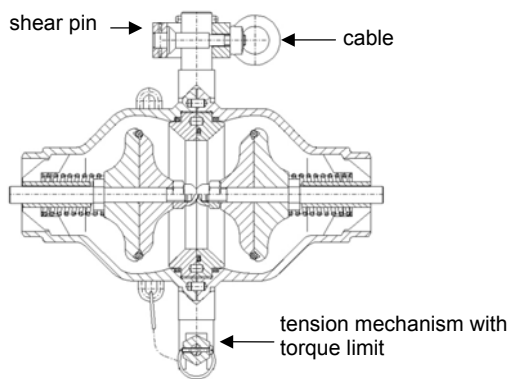

If the connected loading hose is stretched over the allowable working envelope, the cable will be activated.

The shear pin breaks, the clamp plates fall down and the clamp collar of the release unit will unlock.

The two halves of the coupler will divide before parts of the installation and the vehicle can be damaged.

The spring loaded poppets cut the product flow of the hose and the vehicle completely so that leakage will be avoided.

Swivel Joint Assembly

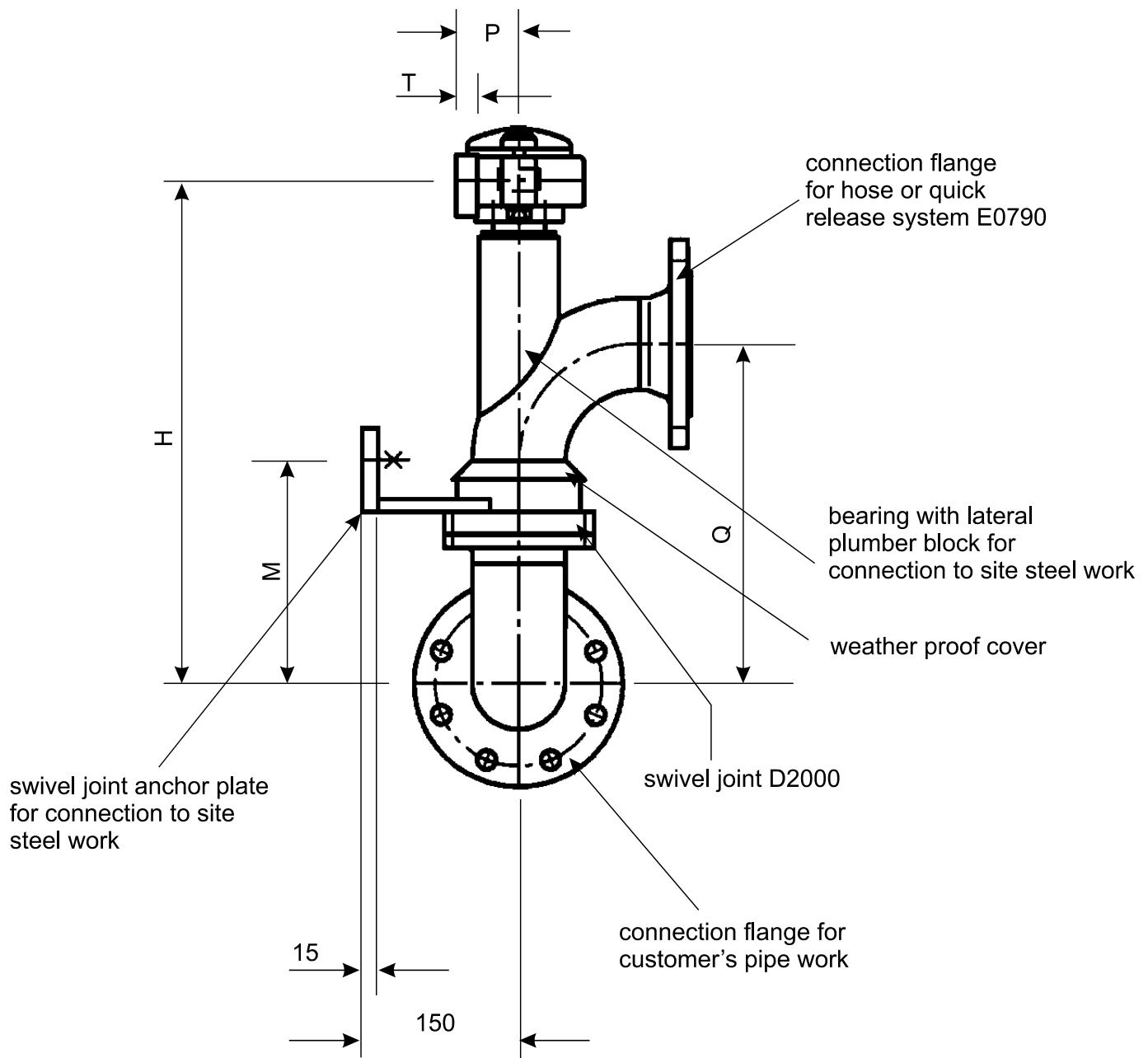

Variant	DN	P	T	H	Q	M
-007	50	60	20	446	250	176
-008	80	60	20	485	327	215
-009	100	80	25	603	403	263