

*Safe Quick Release Coupling  
confirming regulations*

**I. Hydraulic Quick Release System**

- Each the loading arm and the vapour return arm is provided with a quick release system with reduced diameter. The diameter of the system is designed to be 3" for the loading arm and 2" for the vapour return arm.
- The new Emco Wheaton quick release system consists of two usual ball valves and the release coupling, which is clamped together by a collar assembly. Via a lever first the ball valves are closed and then the collar release is activated. Due to the high operating force a hydraulic cylinder is required for the activation.
- The system is controlled hydraulically according to the shown circuit diagram, i.e. with hydraulic limit switch in the slow range between the F- and A-length of the arm.

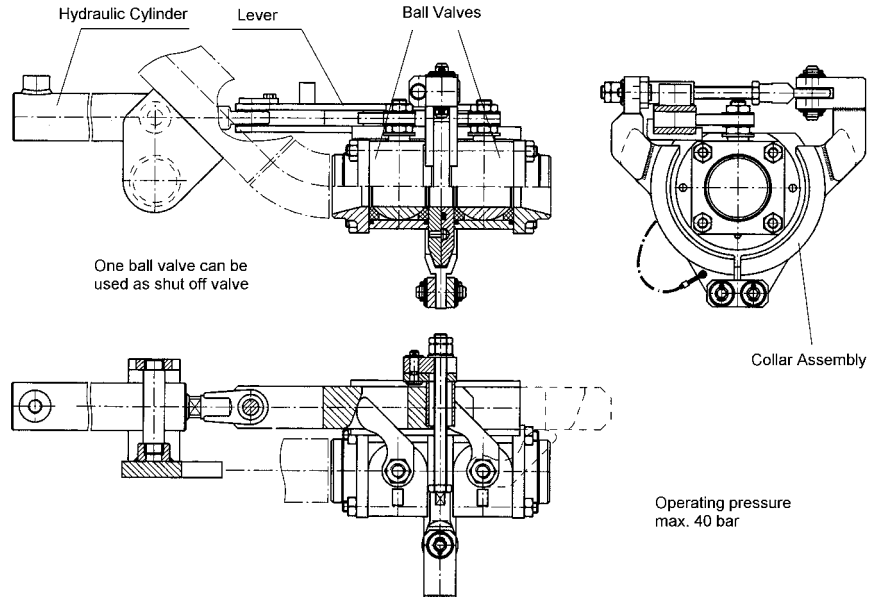

- The release will be initiated either by the product arm or the vapour arm, depending on which one is first outside of its safe working envelope.
- The hydraulic accumulator and the control system are located in a control cabinet with a conductive surface.

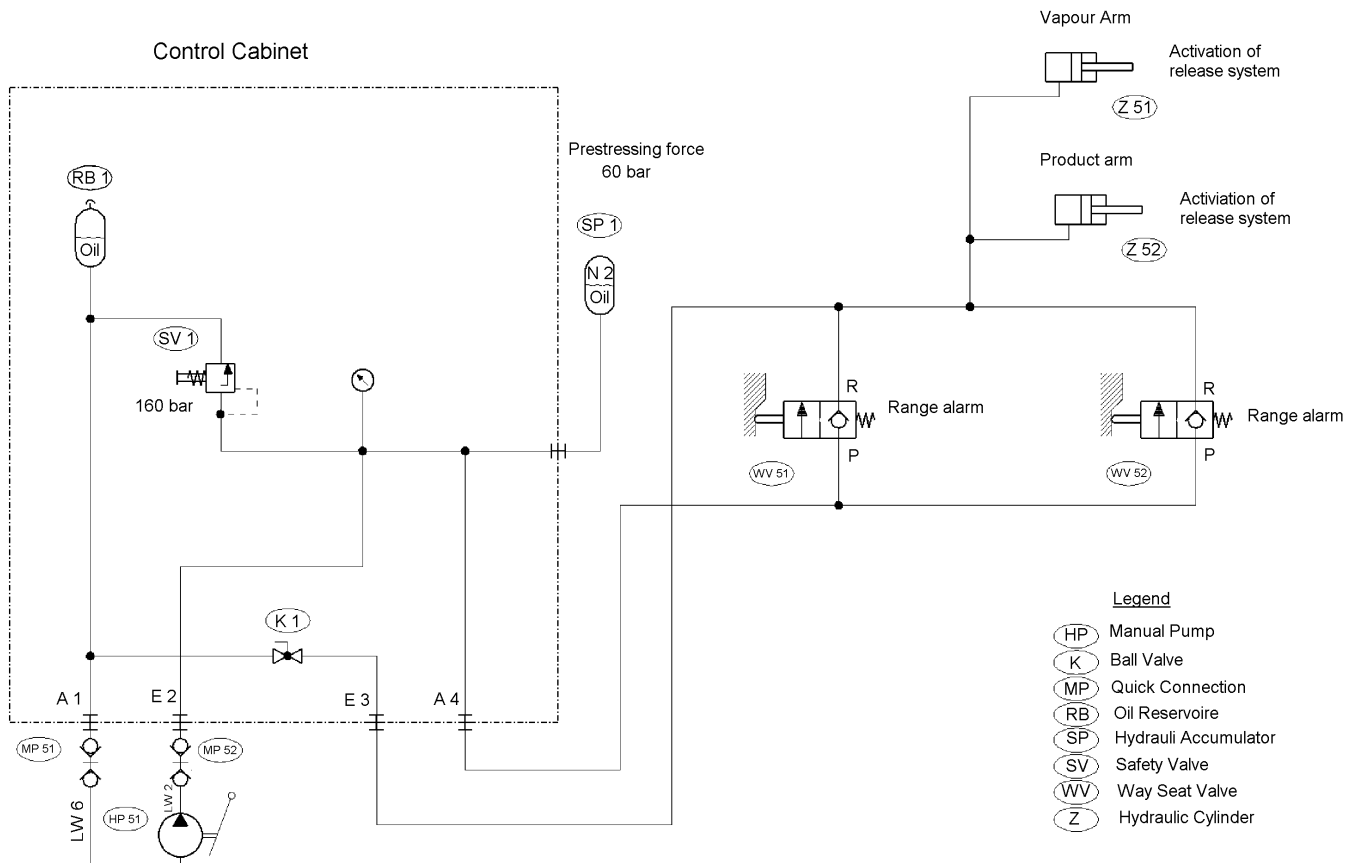

- Legend**
- (HP) Manual Pump
  - (K) Ball Valve
  - (MP) Quick Connection
  - (RB) Oil Reservoir
  - (SP) Hydraulic Accumulator
  - (SV) Safety Valve
  - (WV) Way Seat Valve
  - (Z) Hydraulic Cylinder

## II. Hydro.-Pneum. Quick Release System (power operated by compressed air)

- Each the loading arm and the vapour return arm is provided with a quick release system with reduced diameter. The diameter of the system is designed to be 3" for the loading arm and 2" for the vapour return arm.
- The new Emco Wheaton quick release system consists of two usual ball valves and the release coupling, which is clamped together by a collar assembly. Via a lever first the ball valves are closed and then the collar release is activated. Due to the high operating force a hydraulic cylinder is required for the activation.
- The system is controlled pneum.-hydraulically according to the shown circuit diagram, i.e. with pneumatic limit switch in the slew range between the F- and A-length of the arm.
- The release will be initiated either by the product arm or the vapour arm, depending on which one is first outside of its safe working envelope.
- Once released the signal will be constant for safety reasons to avoid an indifferent indication at slowly drifting tanks. Reset of the signal has to be done manually. The hydraulic cylinders are activated by a hydraulic accumulator and a pressure converter, which is activated by a pneumatically controlled hydraulic valve.
- The hydraulic accumulator and the control system are located in a control cabinet with a conductive surface.
- The pressure converter is a pneumatic cylinder. Its large piston surface is activated with compressed air, so that its small piston surface moves the hydraulic fluid and creates the required pressure for the cylinders of the quick release system.
- The system is explosion prove EEx i, so of the following signals for instance as an alarm at clients installation can be provided

- \* LOADING ARM CONNECTED
- \* AIR PRESSURE SUFFICIENT

